

## Installation Instructions

Model 118  
Chevrolet / GMC  
2001 - 2007 1-Ton



**PopUp**®  
Towing Products  
Mfg by Young's Products, LLC  
4330 Johnson Rd.  
Chanute, KS 66720  
800-837-8578

## MODEL 118 11-2010 FOR THE SAFEST INSTALLATION

- WARNING** Most pick up trucks have **FUEL LINES** and/or **BRAKE LINES** and/or **ELECTRICAL WIRING** positioned along the truck frame rails where your PopUp hitch will install. **BEFORE INSTALLATION** identify and examine the location of fuel lines, brake lines and electrical wires. Do not damage fuel lines, brake lines or electrical wiring when positioning PopUp hitch components, drilling holes or tightening fasteners. **Avoid Fuel Tanks When Drilling Holes.**
- Wear Safety Glasses, Gloves and a Particle Mask while installing a PopUp gooseneck hitch.
  - ALWAYS correctly chock tires prior to raising truck with jacking device.
  - ALWAYS use Jack Stands when working under or around a truck which has been raised by a jacking device.
  - Allow the exhaust system to cool prior to installation to avoid possible burns from hot tail pipe and muffler.

## INSTALLATION PROCEDURE

**CAUTION:** If larger after-market wheels and/or tires have been installed verify adequate Actuating Rod clearance.

**CAUTION:** Before mounting **SNOW CHAINS** verify adequate Actuating Rod clearance. Allow for suspension travel.

**CAUTION:** Verify adequate trailer swing clearance between trailer nose and cab or truck and trailer and rear of truck .

1. Mark and center punch a location from the rear lip of the truck bed centered between the wheel wells for the **specific truck** the hitch is being installed in, as stated below:

Heavy Duty 3500 Series Long Bed Trucks      51 1/8"

Center a 3" hole in this location using a 3" hole saw. Smooth the hole with a file and clean all saw tailings from the bed area before proceeding.

2. Remove the spare tire. If using a vehicle hoist, raise the truck at this time. If using a jacking device Chock the front tires to prevent the truck from rolling. Jacking against the rear bumper or frame, lift the rear of the truck approximately 10". It is not necessary to lift the rear tires off the ground. Properly position jack stands under the rear frame of the truck to protect against jack failure.

3. Remove the entire exhaust heat shield or cut and remove the portion between the bed cross members where the hitch will install. Replace any screws used to secure any sections of heat shield not removed. Cut 1" off of the top of the rearward 4" of the metal shield that protects the fuel tank. This will provide adequate clearance for the Ball Assembly (3).

4. To install the Front Cross Member it is necessary to cut a notch in the lip above the frame where the inner fender and bed floor join. Cut and remove a notch as shown in the illustration 4" ahead of the truck bed sill cross member ahead of the axle where the hitch will install. Pass the Front Cross Member (2) over the frame through the notch and position across the frame rails with the plain side up and with the hole side facing the rear of the truck. Center the Cross Member across the frame rails and 6" ahead of the 3" hole.

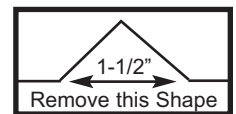

5. Identify the Rear Cross Member 1" X 2" bar (1). Pass it through the driver side wheel well across the top of the frame rails with the bar oriented with the threaded holes nearest the bottom side. Center the Cross Member across the frame rails 3" behind of the 3" hole.

6. With the ball down, and with the hole for the pull rod facing the drivers side of the truck, raise the Ball Assembly (3) into position between the Cross Members with the protruding tube fitting in the 3" hole. On Diesel trucks pop the rubber donuts off the tail pipe and pull the tail pipe down and over for clearance to install Ball Assembly. Place the Eye Bolt (provided) in the threaded hole in the top of the hitch ball and secure it to an overhead lifting device, or to a saw horse in the bed of the truck, and use cable or rope to hold the Ball Assembly firmly against the underside of the bed floor. Fasten the Ball Assembly to the Cross Members using 1/2"bolts and nuts with flat washers over the slotted holes.

7. Fasten the Center Assembly to the Front and Rear Cross Member using flat washers and 1 1/4" x 1/2" bolts. **Pull the slack out of the bolts but do not tighten at this time.** Square the assembled Cross Members and Center Assembly on the truck frame.

## INSTALLATION PROCEDURE - CONTINUED

8. Fasten the Frame Plate tangs to the Crossmembers using 1 1/4" x 1/2" bolts with flat washers and lock nuts. **Pull the slack out of the bolts but do not tighten at this time.**

9. Fasten the Frame Plates to the frame by passing a 3/4" bolt with a flat washer through the lower slotted hole from inside the frame and securing using a flat washer and nut. Drill 1/2" holes in the truck frame through the lower 1/2" hole located in the Frame Plates between the extensions. CAUTION: Avoid fuel tank, brake lines and/or wiring. Pass 1/2" X 1-1/4" bolts with flat washers from inside the frame and secure with flat washers and nuts. **Do not fully tighten at this time.**

10. **Tighten the bolts in the following sequence. First tighten the bolts holding the Center Section to the Cross Bar and Angle. Important: Next, release the Center Section from the overhead lifting device. Check to ascertain that the cross angle and bar are resting securely on the frame.** Next tighten the Frame Plates to the frame, then Cross Members to the Frame Plates, Follow the torque guidelines listed below.

11. Drill four 1/2" holes for the Safety Chain anchors through the pairs of holes closest to the ball in web of channel from under the truck bed. Place a U-bolt in each pair of holes from the top side of the bed. From under the bed place a spring and 1/2" lock nut on each U-bolt leg. Tighten each nut until thread extends through the nut.

12. Pass the Actuating Rod (6) through the slotted hole between the Frame Plate extensions and into the hole in the slide. Align the Actuating Rod and secure using the 1/4" bolt. Seat the bolt in the hole in the rod, and tighten to 7 foot pounds. Ascertain that the rod is free in the frameplate and doesn't drag.

## IMPORTANT!

The final step is to raise the ball and check the position of the slide from under the truck.

When the ball is fully raised, the Roll Pin Stop should be against the ball tube. This allows the Detent Ball to lock the slide in place and positions the ball over the flat surface at top of the slide.

In this position it is impossible for the ball to retract without manually pushing in the handle.

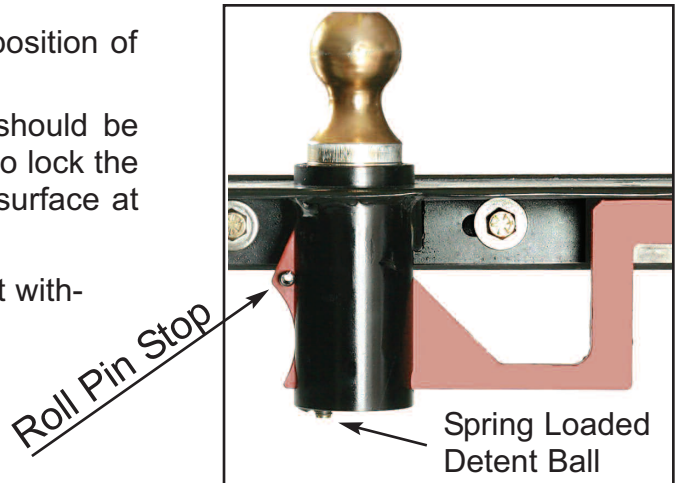

Read the **SAFE TOWING INSTRUCTIONS** on the **PopUp Warranty** sheet.

### HARDWARE PROVIDED

- 14 - 1/2" X 1-1/4" Grd. 8 Bolts
- 12 - 1/2" Lock Nuts
- 14 - 1/2" Flat Washers
- 2 - 3/4" X 2" Grd. 5 Bolts
- 2 - 3/4" Nuts
- 4 - 3/4" Flat Washers
- 2 - U-Bolts & Springs
- 1 - 3/8" Eyebolt
- 1 - Plastic Cap

Torque 1/2" Grade 8 Bolts to 65 ft. lbs,  
3/4" bolts to 70 ft. lbs.

[www.popuphitch.com](http://www.popuphitch.com)

**Model Number 118**  
**Gross Trailer Weight: 30M lbs.**  
**Gross Trailer Tongue Weight: 7.5M lbs.**

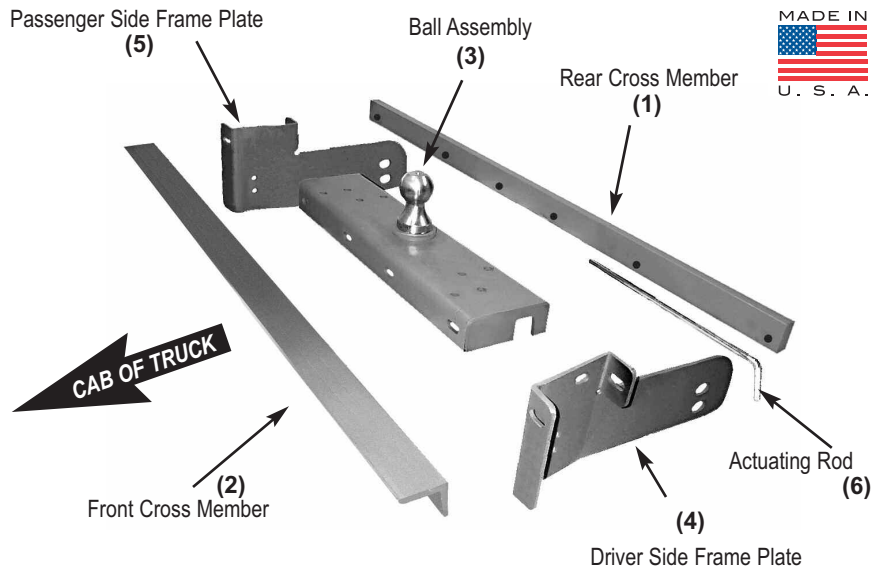

# IMPORTANT!

Before installing the actuating rod place the indicator / lock collar on the rod toward the bend for the handle.

As a last step firmly pull the handle to raise the ball, verify that the Roll Pin Stop is against the ball tube. Then slide the indicator / lock collar against the outside of the frame plate and secure it in this position using a 1/8" allen wrench.

With the indicator / lock collar in place raise the actuator rod slightly and push in to lower the ball. To raise the ball raise the handle and pull the actuator rod out till the indicator / lock collar clears the frame plate. This gives a positive indication that the ball is fully raised and is ready for towing.

**PopUp**<sup>®</sup> Towing Products  
Mfg by Young's Products, LLC

Indicator /  
Lock Collar

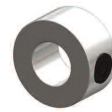

Frame  
Plate

