



Installation Instructions

Model 129

Dodge Mega Cab

Fits 2006-2007 1/2, 3/4 & 1 Ton
Short Bed

PopUp™

Safari Industrial Park
4330 Johnson Road
Chanute, KS 66720
877-339-5704
info@popuphitch.com
www.popuphitch.com
US Patent 6,447,000

Model 129C 9/05

FOR THE SAFEST INSTALLATION

WARNING Most pick up trucks have **FUEL LINES** and/or **BRAKE LINES** and/or **ELECTRICAL WIRING** positioned along the truck frame rails where your PopUp hitch will install. **BEFORE INSTALLATION** identify and examine the location of fuel lines, brake lines and electrical wires. Be sure you will not damage fuel lines, brake lines or electrical wiring when positioning the hitch components, drilling holes or tightening fasteners. **Be Certain To Avoid Fuel Tanks When Drilling Holes.**

- Wear Safety Glasses, Gloves and Particle Mask for protection while installing a PopUp gooseneck hitch.
- ALWAYS correctly chock tires prior to raising truck with jacking device. For protection in case of jacking device failure ALWAYS use Jack Stands when working under or around a truck which has been raised by a jacking device.
- Be certain the exhaust system is cool prior to installation to avoid possible burns from hot tail pipe and muffler.
- Torque ALL fasteners used in the PopUp gooseneck hitch installation as specified in these Installation Instructions.

INSTALLATION PROCEDURE

WARNING: Verify adequate trailer swing clearance between trailer nose and cab of truck, and trailer and rear of truck.

1. Mark and center punch a location at **45-1/2"** from the rear lip of the truck bed floor (tailgate end) centered between the wheel wells. Use a 3" hole saw to cut a hole in the bed floor centered at this location. Smooth hole edges with file after sawing. Clean all saw tailings from the bed area before proceeding.
2. Remove the spare tire. If so equipped, cut and remove the tail pipe heat shield between the two truck bed cross members ahead of and rearward of the axle where the hitch will install.
3. In the driver side rear wheel well, locate the 7/16" hole over the axle on the lip formed where the bed floor and fender well are welded together. It is necessary to remove the lip below this hole to allow the cross members to be passed across the top of the frame rails. Cut the metal away under the hole as shown.
4. Pass the Front Bar Cross Member (2) across the frame rails of the truck from the driver side with the 1/4" spacers on the bottom for 3/4 and 1 ton trucks or on the top for 1/2 ton trucks. Center the Front Bar Cross Member across the frame against the truck bed sill in front of the 3" hole.
5. Pass the Rear Angle Cross Member (1) across the frame rails similarly, with the plain side (2" leg) up and with the hole leg facing forward. Center the Rear Angle Cross Member across the frame against the truck bed sill behind the 3" hole in the bed floor.
6. With the ball down, and with the cam facing the front of the truck, slide the Center Assembly (3) over the exhaust pipe and into position between the Cross Members with the ball tube fitting into the 3" hole. Place the Eye Bolt (provided) in the threaded hole in the top of the hitch ball and secure it to an overhead lifting device, or to a saw horse in the bed of the truck, and use cable or rope to hold the Ball Assembly firmly against the underside of the bed floor. Insure that the top of the Ball Assembly channel is flush with the bottom of the bed floor.
7. Fasten the Ball Assembly to the Front Cross Member using 1/2" X 1-1/2" bolts with washers only on the slotted holes inside the channel. **DO NOT use washers on the two center holes.** Slide the Rear Cross Member forward and fasten it to the Ball Assembly by passing 1/2" X 1-1/2" bolts with washers from inside the channel and securing with 1/2" nuts. Do not fully tighten at this time.
8. Identify the driver side Frame Plate (4, with labels) and passenger side Frame Plate (5). Position the Frame Plate extension tabs between the Cross Members. Remove the brake cable bracket. Fasten to the Front Cross Member using a flat washer and 1/2" X 1-1/2" bolt through the bent tang of the Frame Plate. Fasten to the Rear Cross Member by passing a 1/2" X 1-1/2" bolt with a flat washer from the Frame Plate and securing with a flat washer and 1/2" nut. Do not fully tighten these fittings at this time.
9. Be certain the hitch is square across the frame front to back and side to side.

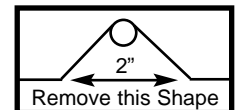

INSTALLATION PROCEDURE - CONTINUED

10. Secure the Frame Plates to the frame using Clamping Plates (7&8) and four 1/2" bolts and lock nuts. **Note:** Front and Rear Clamping Plates are different. *Rear Plates have one rounded corner.* Use the 1/2" X 4-1/2" carriage bolt for the Driver Side Frame Plate passed from outside the frame through the top forward square hole. Use 1/2" X 4-1/2" bolts passed through the Clamping Plates from inside the frame in the other holes. Use the lower holes for 3/4 and 1 ton trucks. Use the center holes for 1/2 ton trucks.

CAUTION: Carefully follow these instructions for tightening Frame Plate fasteners: It is important to ALTERNATELY tighten fasteners to draw the Clamping Plates evenly against the inside of the frame. Torque these fittings to precisely 55 Foot Pounds. **Use a Torque Wrench.**

11. Install a self-tapping 3/8" bolt into the frame through the center hole (9) of each frame plate. Use a letter "T" bit (11/32" can be substituted) to drill a hole in the frame after starting the hole using a 3/8" bit for centering. Torque the self-tapping bolt to 15 Foot Pounds. Mount removed Brake Cable Bracket with 5/16" carriage bolt and nut in square hole provided in Driver Side Frame Plate.

12. Torque all the fittings between the Cross Members and Center Assembly and Frame Plates to 65 Foot Pounds.

13. Pass the Actuating Rod (6) through the 1/2" X 3/4" **Oval Hole** between the Frame Plate extensions on the driver side and into the linkage coupler. Using the 1/4" bolt or set screw, align the Actuating Rod so the set screw seats in the hole in the rod and torque to 7 foot pounds. Remove some of the lip above where the Actuating Rod installs to allow free travel.

14. Drill four 1/2" holes for the Safety Chain Brackets from under the truck bed. Place a U-bolt in each pair of holes from the top side of the bed. From under the bed place a spring and 1/2" nut on each U-bolt leg. Tighten each nut until thread extends through the nut.

HITCH BALL OPERATION

WARNING: ALWAYS WEAR GLOVES FOR PROTECTION WHEN RAISING OR LOWERING HITCH BALL.

1. Read the **SAFE TOWING INSTRUCTIONS** and the **OPERATION AND MAINTENANCE INSTRUCTIONS.**

2. Raise and Retract the hitch ball with the Actuating Rod located in the driver side rear wheel well. Raise the hitch ball by firmly pulling the actuating rod to its maximum extension. Retract and Raise the hitch ball every couple of weeks. **Note: Always make certain the hitch ball is fully raised before coupling to a trailer.** When the hitch ball is fully raised, a line cut around the neck of the hitch ball is visible at the tube. Retract the hitch ball by pushing the Actuating Rod to its seated position. (A bump with the heel of the hand on the Actuating Rod will release the raised hitch ball.)

3. Retract and Raise the hitch ball frequently. The cam/ball mechanism is best lubricated with a generous spray of WD-40.

4. Insert the Plastic Cap (provided) into the tube for protection from accumulation of debris in the top of the tube when the ball is retracted. The Plastic Cap will pop out when the ball is raised. Protection from debris can also be achieved by leaving the ball in the raised position when a level bed is not required.

5. It may be necessary to remove debris allowed to accumulate in the top of the tube while the hitch ball is retracted and not protected with the Plastic Cap. Insert the Eye Bolt in the ball and lift the ball using a screw driver to displace debris and free the ball.

6. **Lubrication:** The ball mechanism is best lubricated with a spray of WD-40 lubricant in the top of the tube. Coat the ball with a light film of lithium grease. **DO NOT USE** a heavy coating of gun or wheel bearing grease. Excess heavy grease does not increase protection. Excess heavy grease will migrate into the tube and make it difficult or impossible to remotely raise and lower the PopUp hitch ball.

HARDWARE PROVIDED

- 12 - 1/2" X 1-1/2" Grd. 8 Hex Bolts
- 7 - 1/2" X 4-1/2" Grd. 8 Hex Bolts
- 1 - 1/2" X 4-1/2" Grd. 8 Carriage Bolt
- 20 - 1/2" Hex Lock Nuts
- 14 - 1/2" Flat Washers
- 4 - Clamping Plates
- 2 - 3/8" Self Tapping Bolts
- 1 - 1/4" Set Screw
- 2 - U-Bolt Assemblies
- 1 - 5/16" X 3/4" Carriage Bolt
- 1 - 5/6" Nut

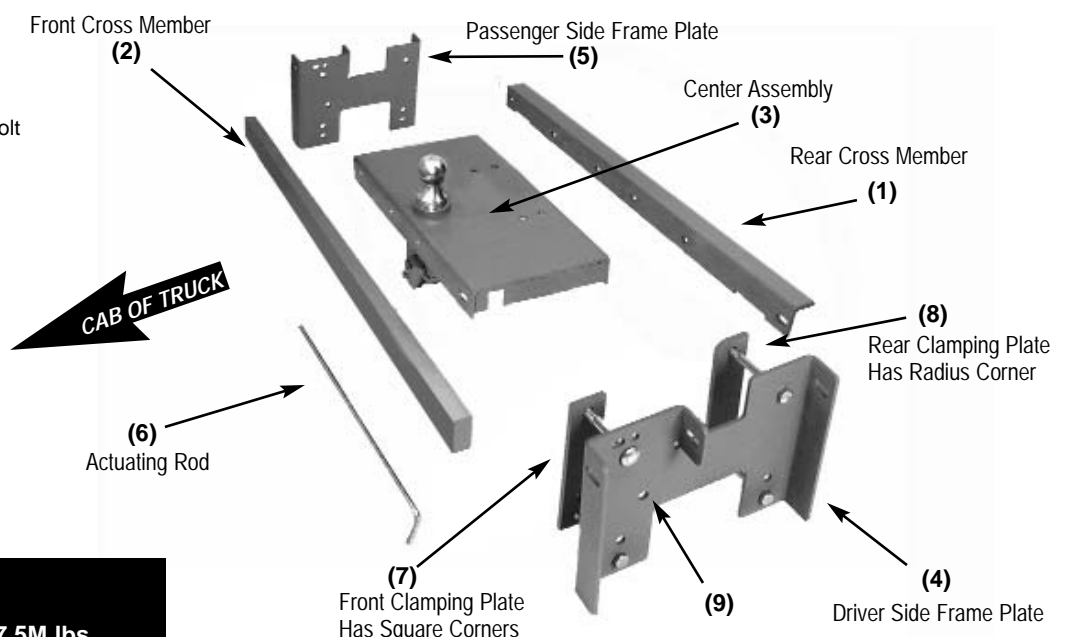

Model Number 129

Gross Trailer Weight: 30M lbs.

Gross Trailer Tongue Weight: 7.5M lbs.